



Hydraulic Tunnel Thrusters

- Ideal for commercial and heavy displacement / high windage vessels from 40'-85'
- Designed for long-term performance
- Corrosion free components

FEATURES:



Corrosion free **composite drive legs** eliminate the need for periodic anode changes and offer high manufacturing tolerances.



Case hardened spiro-conical gears guarantee a silent, smooth and durable drive leg.



Drive legs are pre-filled with oil and sealed for life for **zero maintenance**.



Line shields protect oil seals from fishing lines & fouling, ensuring maintenance free operation.



Highly reputed brand of hydraulic motors used to ensure durability and serviceability.

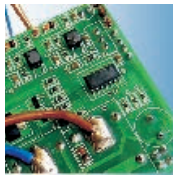

Electronic control boxes offering **unrivaled safety features** to protect against accidental misuse.

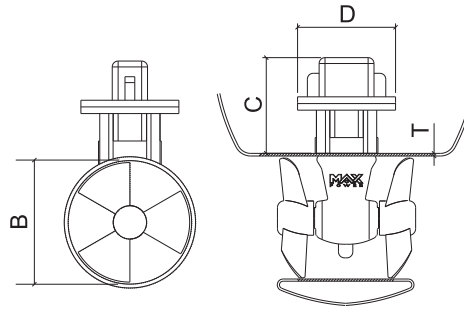

THRUSTERS

Hydraulic Tunnel Thrusters

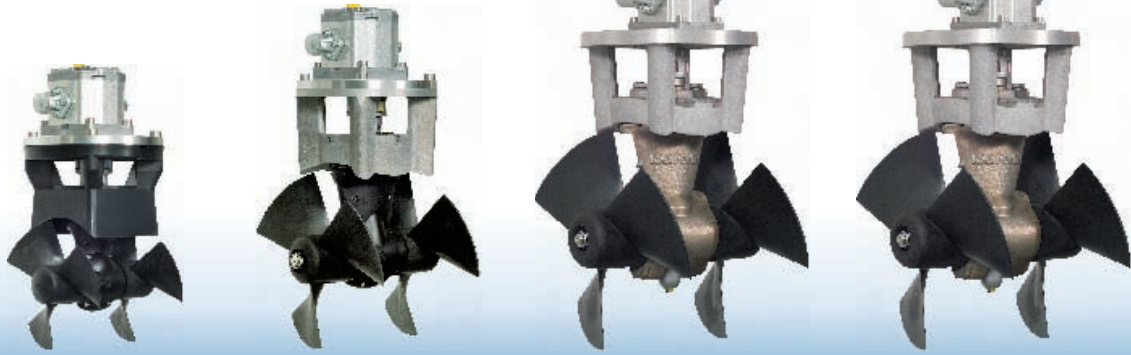

Model No.	CT HYD 125	CT HYD 225	CT HYD 325/250	CT HYD 325/325
Composite	MPHYC810 (6cc) MPHYC815 (8cc) MPHYC800 (11cc)	MPHYC1100	-	-
Bronze			MPHY3150	MPHY3155
Tunnel Diameter	7.25" / 185mm	10" / 250mm	12.4" / 315mm	12.4" / 315mm
Propellers	2	2	2	2
Thrust	242 lb / 110 kg	396 lb / 180 kg	462 lb / 210 kg	584 lb / 265 kg
Flow	33 / 35	33 / 35	35 / 38	38 / 45
Pressure (bar)	130 > 140	200 > 220	200 > 220	200 > 220
Weight	27 lb / 12 kg	42 lb / 19 kg	53 lb / 24 kg	117 lb / 53 kg
Measurements				
B	7.3" / 185mm	9.9" / 250mm	12.4" / 315mm	12.4" / 315mm
C	8.5" / 215mm	8.7" / 220mm	9.5" / 240mm	9.5" / 240mm
D	8.3" / 210mm	8.7" / 220mm	10.6" / 270mm	10.6" / 270mm
T	.24-.28" / 6-7mm	.28-.32" / 7-8mm	.35-.39" / 9-10mm	.35-.39" / 9-10mm