

Ignition Protected Electric Tunnel Thrusters

- Allows the safe use of an electric thruster in gas engine powered vessels where there may be potentially flammable gases
- Ignition Protected to ISO 8846 standard
- Can also be installed in habitually wet or damp areas

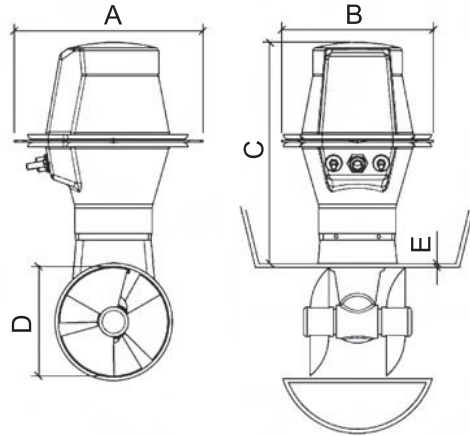

THRUSTERS

Ignition Protected Thrusters



Model No.	CT35-IP	CT45-IP	CT60-IP		CT80-IP		CT100-IP	CT125-IP
Part No	MPSPC212/IP	MPSPC312/IP	MPSPC412/IP	MPSPC424/IP	MPSPC512/IP	MPSPC524/IP	MPSPC812/IP	MPSPC824/IP
Voltage	12v	12v	12v	24v	12v	24v	12v	24v
Tunnel Diameter	5" / 125mm	5" / 125mm	7.25" / 185mm	7.25" / 185mm	7.25" / 185mm	7.25" / 185mm	7.25" / 185mm	7.25" / 185mm
Propellers	1	2	1	1	2	2	2	2
Power (kW)	2.69	3.23	4.35	4.4	4.79	5.28	7.1	8.56
Horsepower	3.6	4.3	5.8	5.9	6.4	7.1	9.5	11.5
Thrust	77 lbs / 35 kg	88 lbs / 40 kg	128 lb / 58 kg	138 lbs / 63 kg	152 lb / 69 kg	145 lb / 75 kg	212 lb / 96 kg	253 lb / 115 kg
Weight	26lb / 11.6 kg	26lb / 11.65 kg	39 lb / 17.5 kg	39 lb / 17.5 kg	39 lb / 17.6 kg	39 lb / 17.6 kg	60 lb / 27.2 kg	60 lb / 27.2 kg
Measurements								
A	11.9" / 301mm	11.9" / 301mm	12.6" / 320mm		12.6" / 320mm		15.4" / 390mm	15.4" / 390mm
B	9.1" / 230mm	9.1" / 230mm	10.2" / 255mm		10.2" / 255mm		12.0" / 305mm	12.0" / 305mm
C	11.6" / 295mm	11.6" / 295mm	14.8" / 375mm		14.8" / 375mm		19.3" / 490mm	19.3" / 490mm
D	4.9" / 125mm	4.9" / 125mm	7.3" / 185mm		7.3" / 185mm		7.3" / 185mm	7.3" / 185mm
E	.16-.2" / 4-5mm	.16-.2" / 4-5mm	.20-.24" / 5-6mm		.20-.24" / 5-6mm		.20-.24" / 5-6mm	.20-.24" / 5-6mm